

THE BEST LEVEL OF PROTECTION

SAFETY FROM ABOVE



2024 CATALOG

HALOTM

ROLLOVER OCCUPANT PROTECTION SYSTEM

WWW.HALOROPS.COM

HALOTM
ROLLOVER OCCUPANT PROTECTION SYSTEM



SAFETY FROM ABOVE

SEI

Safety Engineering International

Safety Engineering International is a vehicle safety engineering company. Our design engineers have years of experience in rollover accident investigation and dynamic vehicle testing which allows them to gain a better understanding of how injuries occur in rollovers and what precautions can be taken to prevent serious injuries. These findings are the building blocks for our HALO Rollover Occupant Protection System (ROPS).

OUR CLIENTS



DE BEERS GROUP

KOMATSU



RioTinto



HALO CHARACTERISTICS



The HALO consists of a geometrically optimized tubular structure mounted on the vehicle roof and a system of internal reinforcement plates below the internal trim panels.

HALO distributes the force across the vehicle's vertical pillars, while drawing on the vertical support added by internal reinforcements.

HALO doesn't interfere with any internal safety equipment such as side or curtain airbags, or seat belt pretensioners.

Weighing between 40 to 50 kilograms, the HALO doesn't affect the vehicle's center of gravity or reduce fuel efficiency.

HOW THE HALO WORKS

The HALO's patented design adds an external roll hoop that changes the rolling geometry of the vehicle.

A) Without HALO, the CG drops to the Minor Radius and the weak roof collapses on the trailing side corner.

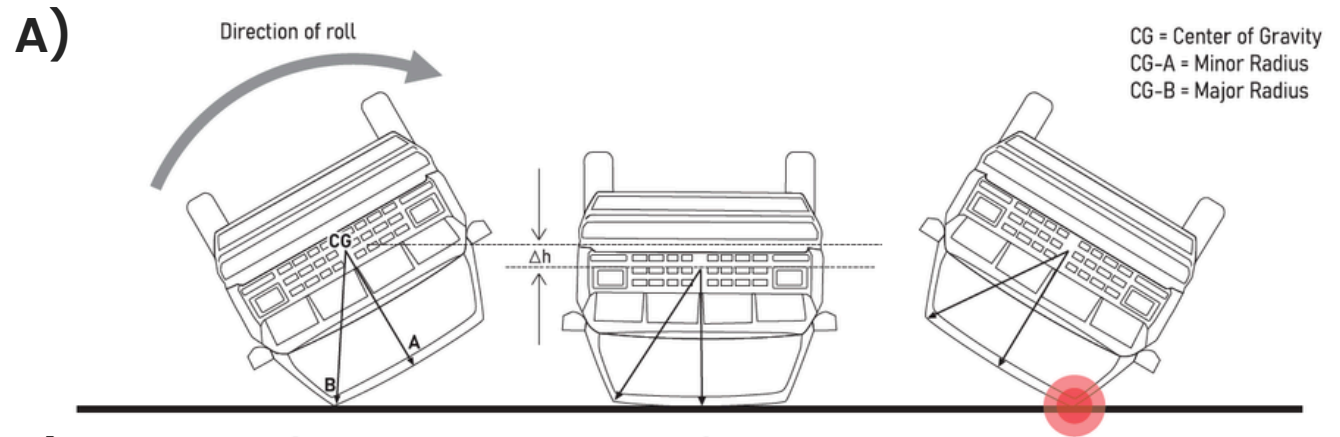

B) With HALO: The CG maintains the Major Radius and prevents collapse on the trailing side corner.

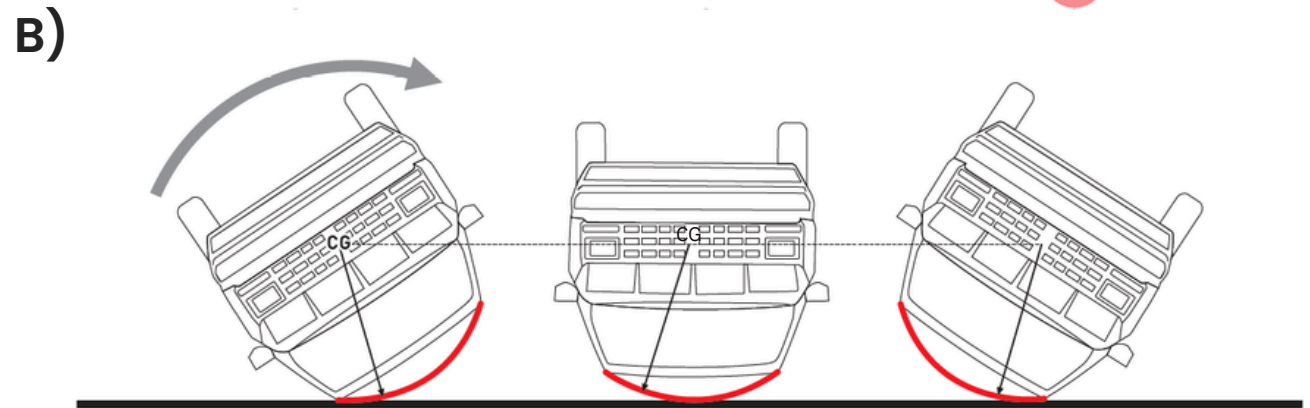

- Maintains the vehicle's roll radius characteristic allowing the vehicle body to roll more smoothly.
- Distributes the roof loads across the roof surface allowing for smooth and even roof structure ground loading.
- Minimizes roof intrusion and speed at the A and B Pillars which keeps the roof up and away from the occupants.

RESEARCH AND TESTING

Dynamic Prototype Testing

50th Percentile Dummy in Rollover Test
Minimal injury measures recorded.



Pre-test

After 3 full rollover tests

Strength to Weight Ratio Testing

Evaluation of HALO under FMVSS No. 216
Roof Crush Resistance Standard

SWR Without HALO

ROPS: 2.34

SWR With HALO

ROPS: 6.13

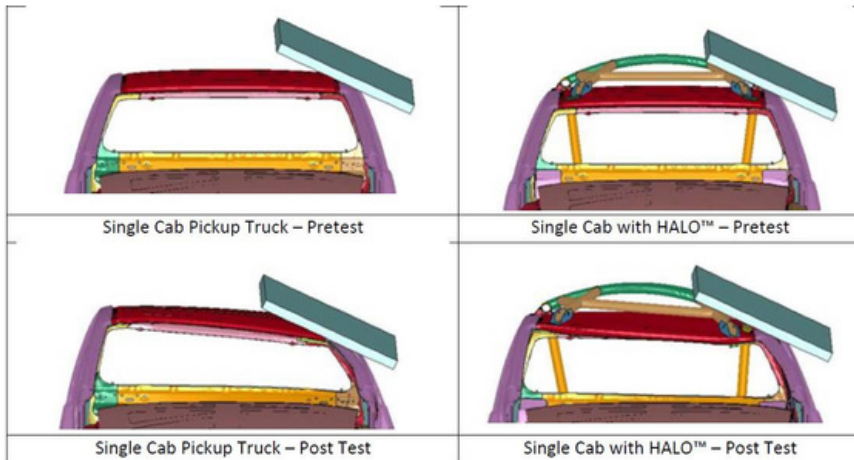

HALO equipped vehicles are x3 STRONGER!

HALO SAVES LIVES

REAL WORLD RESULTS

Thousands of trucks all over the world are equipped with our products protecting lives. In over 80 rollover accidents, there were no injuries to the belted occupants of these vehicles. The HALO keeps the occupant survival space intact and your workers safe.



HALOTM
ROLLOVER OCCUPANT PROTECTION SYSTEM

SAFETY FROM ABOVE

BRAND MAKES

HALO ROPS is available for a variety of brands, with multiple models per brand to choose from. We have both new and older model versions of HALO that have been custom designed to fit the vehicle.



DESIGN SERVICES

We can design a HALO ROPS for any type of vehicle. If you don't see a brand or model that you wish to purchase, please contact us with your inquiry at info@safetyei.com

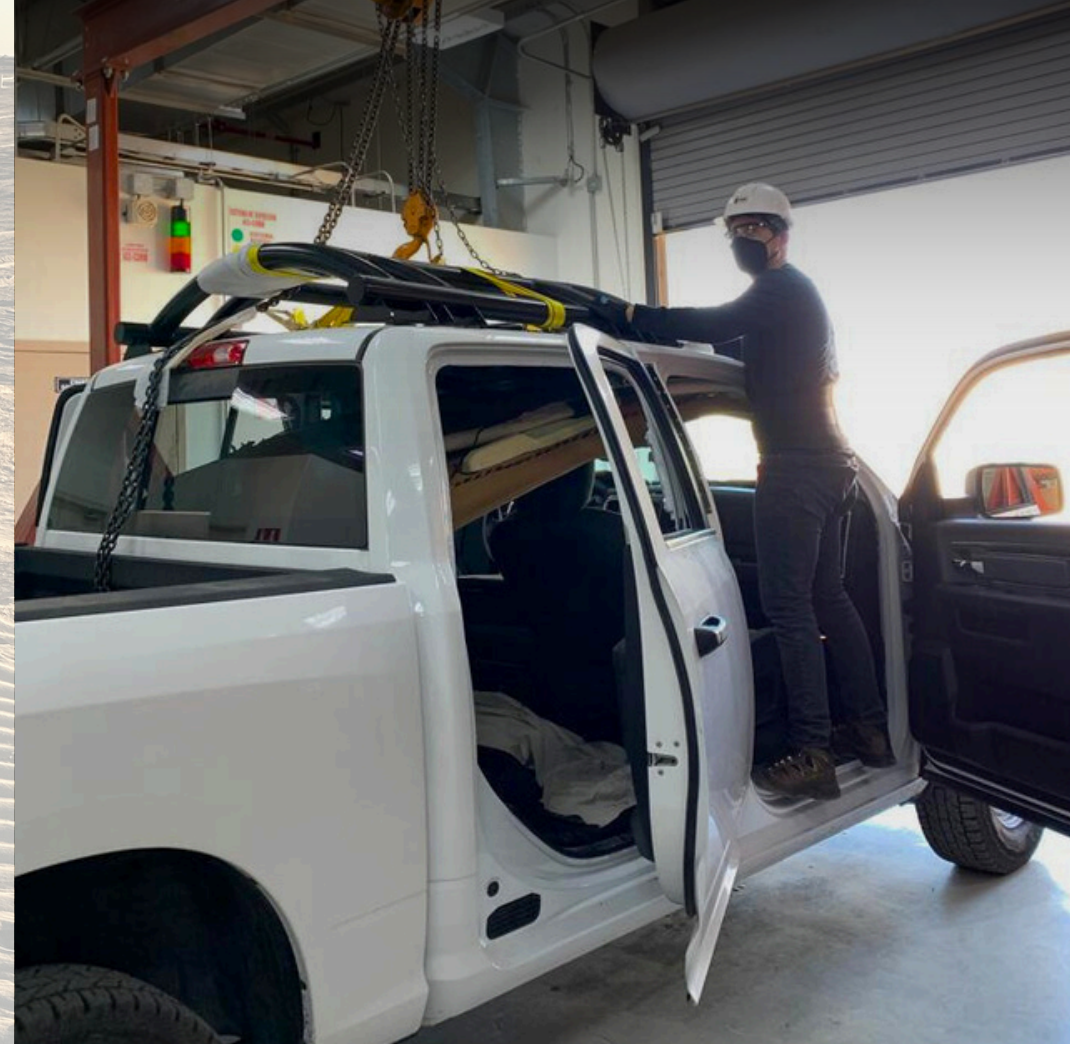

DOUBLE CAB TRUCKS



H15 TOYOTA LANDCRUISER 79 DUAL CAB



H16 TOYOTA HILUX DUAL CAB



H18 MAHINDRA PIK UP DUAL CAB



H26 FORD RANGER DUAL CAB

SINGLE CAB TRUCKS



H14 TOYOTA LANDCRUISER 79 SINGLE CAB



H23 ISUZU GEN 7 SINGLE CAB



H24 FORD RANGER SINGLE CAB



H17 TOYOTA HILUX SINGLE CAB

THE BEST LEVEL OF PROTECTION

WWW.HALOROPS.COM

HALO MODELS

MAKE	YEAR RANGE	MODEL
DODGE RAM 1500/2500 SINGLE CAB	2016 - 2022	HR15S
DODGE RAM 1500/2500 DOUBLE CAB	2016 - 2022	HR15D
FORD RANGER DOUBLE CAB	2013 - 2022	H9AKIT
FORD RANGER SINGLE CAB	2016 - 2022	H24AKIT
FORD RANGER DOUBLE CAB	2023 +	H26AKIT
FORD RANGER SINGLE CAB	2023 +	H25AKIT
FORD F-250/F-350 DOUBLE CAB	2018 - 2022	HF25D
ISUZU KB250 DMAX SINGLE CAB	2014 - 2022	H11AKIT
ISUZU KB250 DMAX DOUBLE CAB	2014 - 2022	H12AKIT
ISUZU GEN 7 DOUBLE CAB	2023 +	H22AKIT
ISUZU GEN 7 SINGLE CAB	2023 +	H23AKIT
JAC FRISON T6 & T8	2022 +	H27AKIT
MAZDA BT-50 DOUBLE CAB	2015 - 2022	H3AKIT
MAHINDRA PIK UP DOUBLE CAB	2019 +	H18AKIT
MITSUBISHI L200 DOUBLE CAB	2010 - 2015	H5AKIT
MITSUBISHI L200 DOUBLE CAB	2016 +	H51AKIT
NISSAN NP300 HARDBODY DOUBLE CAB	2015 +	H13AKIT
NISSAN NP300/NAVARA DOUBLE CAB	2016 +	H19AKIT
NISSAN NP300/NAVARA SINGLE CAB	2016 +	H21AKIT
TOYOTA HILUX DOUBLE CAB	2010 - 2015	H6AKIT
TOYOTA HILUX SINGLE CAB	2010 - 2015	H10AKIT
TOYOTA HILUX DOUBLE CAB	2016 +	H16AKIT
TOYOTA HILUX SINGLE CAB	2016 +	H17AKIT
TOYOTA LANDCRUISER 79 SINGLE CAB	2014 +	H14AKIT
TOYOTA LANDCRUISER 79 DOUBLE CAB	2015 +	H15AKIT



WORLD WIDE DISTRIBUTION

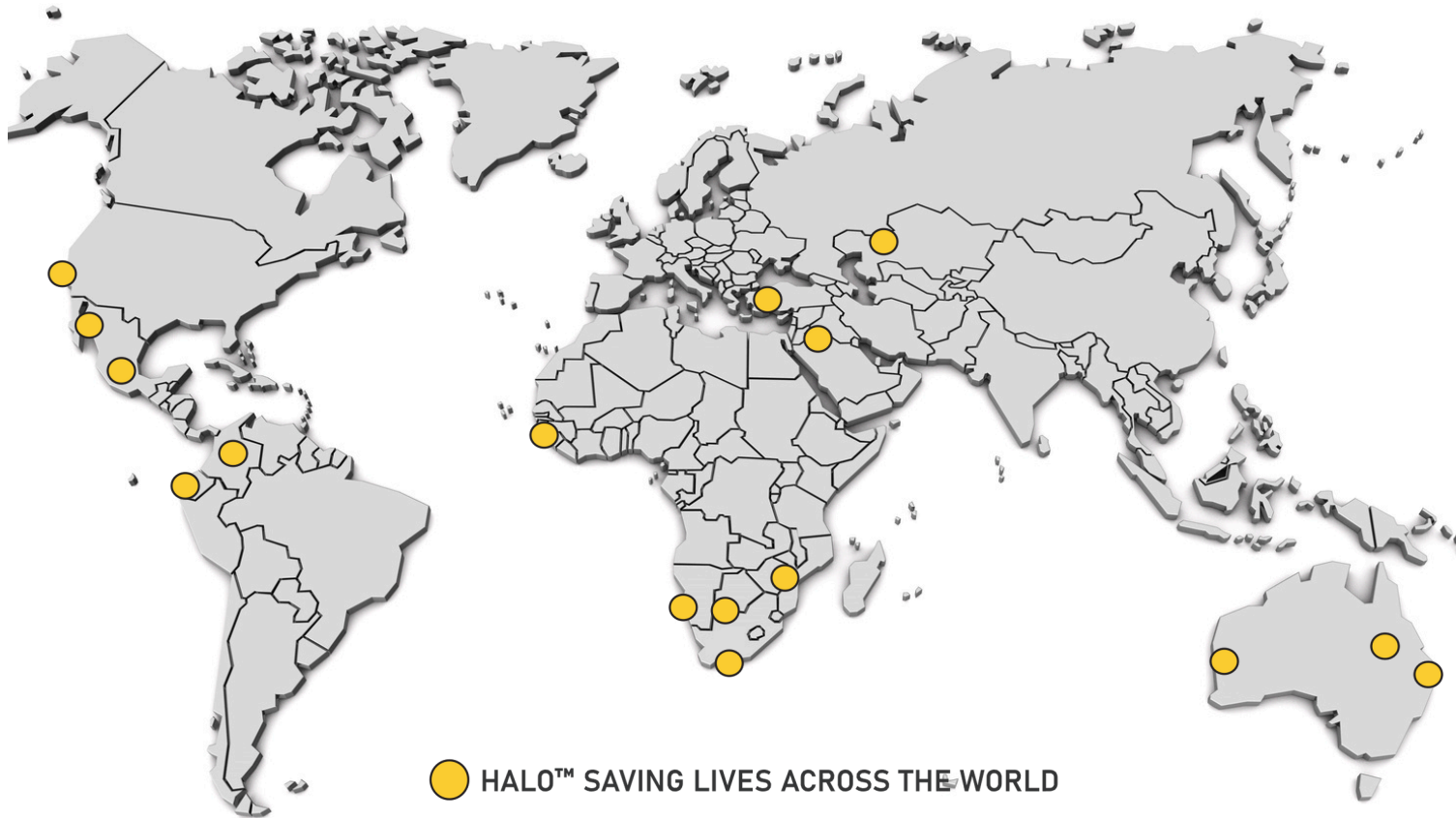

MEXICO AND SOUTH AMERICA

INGIENERIA EN SEGURIDAD VEHICULAR SEI

Javier Valadez
serviciohalo@safetyei.com
+52 811-050-7704

AFRICA AND MIDDLE EAST

SAFETY ENGINEERING INTERNATIONAL

Susie Bozzini
info@safetyei.com
+1 805-895-5192

SEI

Safety Engineering International

SAFETY FROM ABOVE



USA | CANADA | ASIA | OCEANIA

Safety Engineering International, LLC

5949 Hollister Ave Suite C

Goleta, California USA 93117

+1 805-895-5192 info@safeteyei.com

Follow us on social media for news and product launches:



HALO Rollover Occupant Protection System



@halorops



Halorops



@halorops



ISO 9001:2015 Quality Management
Certified Manufacturing

INTELLECTUAL PROPERTY: Patents & Copyrights: United States, South Africa, Australia, Singapore, Mexico, Canada, Brazil, India, Korea

SEI and HALO logos are registered marks of Safety Engineering International © 2024. All rights reserved.